

ROCKY  KNOB

ESTATES



The City of Young Harris is located in the picturesque North Georgia Mountains, less than two hours from Atlanta, Asheville, and Chattanooga. Rocky Knob Estates overlooks the famous Brasstown Valley Resort, just minutes to the shores of Lake Chatuge and downtown Hiawassee.



Premier mountaintop home sites range from one to two acres with spectacular panoramic vistas. A mile long border with the USFS adds to the stunning views of the Resort's Championship Golf Course and Lakes. Picture perfect forested mountain peaks makes this a community of distinction.



A breath of fresh air in a nature sanctuary with a gated entrance, easily navigated paved roads, county water, fiber optics, fire hydrants, and underground utilities. All are included in this second to none mountaintop living experience.



ROCKY  KNOB
ESTATES



ROCKY KNOB ESTATES

~ Gated Community ~

~ No Steep Roads ~

~ Fire Hydrants ~

~ County Water ~

~ Fiber Optics ~

~ Paved Roads ~

~ Borders U.S. Forest Service ~

**** Brasstown Valley Resort Golf Membership ****

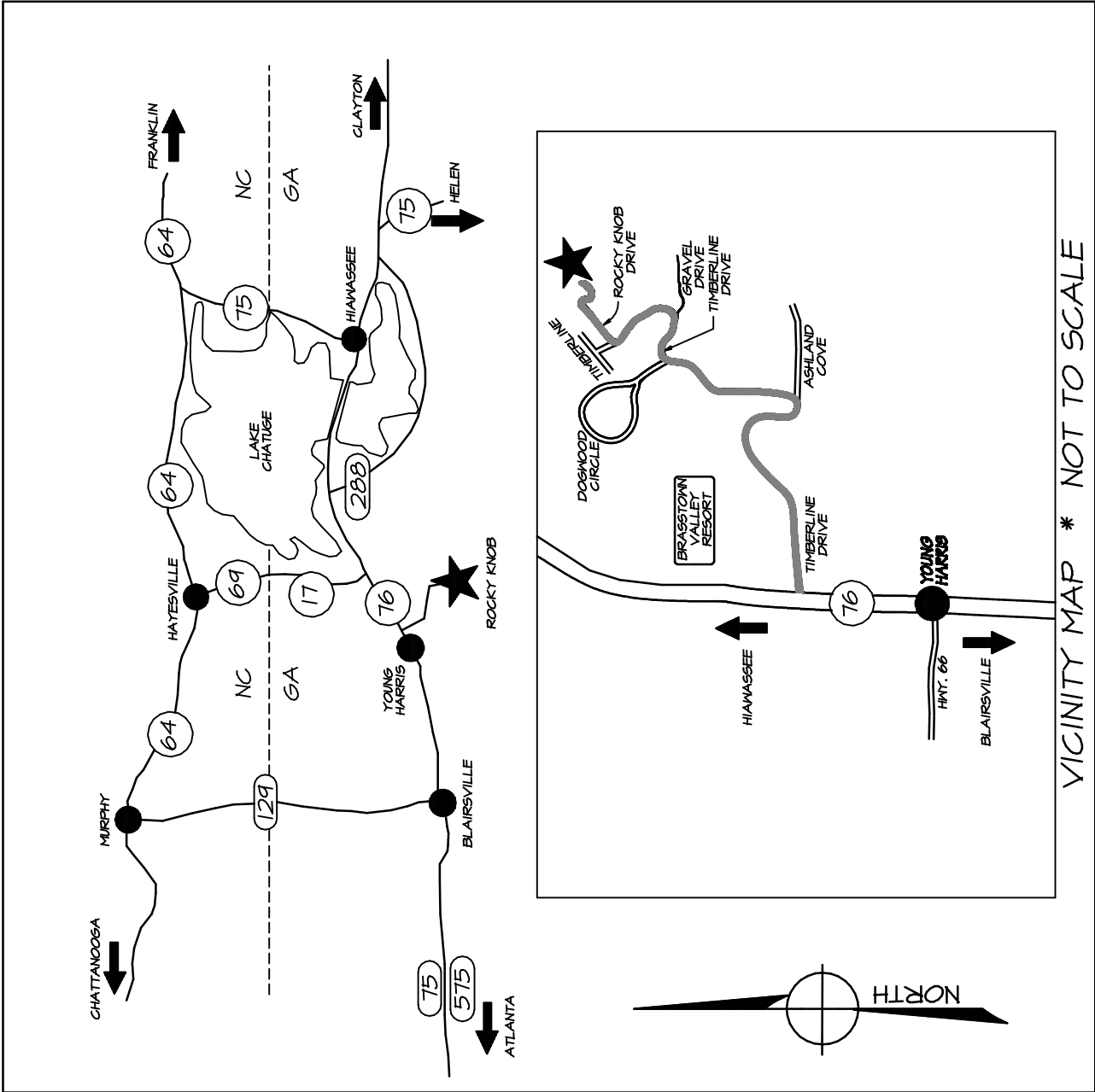

VICINITY MAP * NOT TO SCALE

ROCKY KNOB ESTATES



Landtech
SERVICES, INC.
"Knowledge Through Experience"

**GREEN MOUNTAIN DEVELOPMENT
INQUIRES: 706-856-6469**

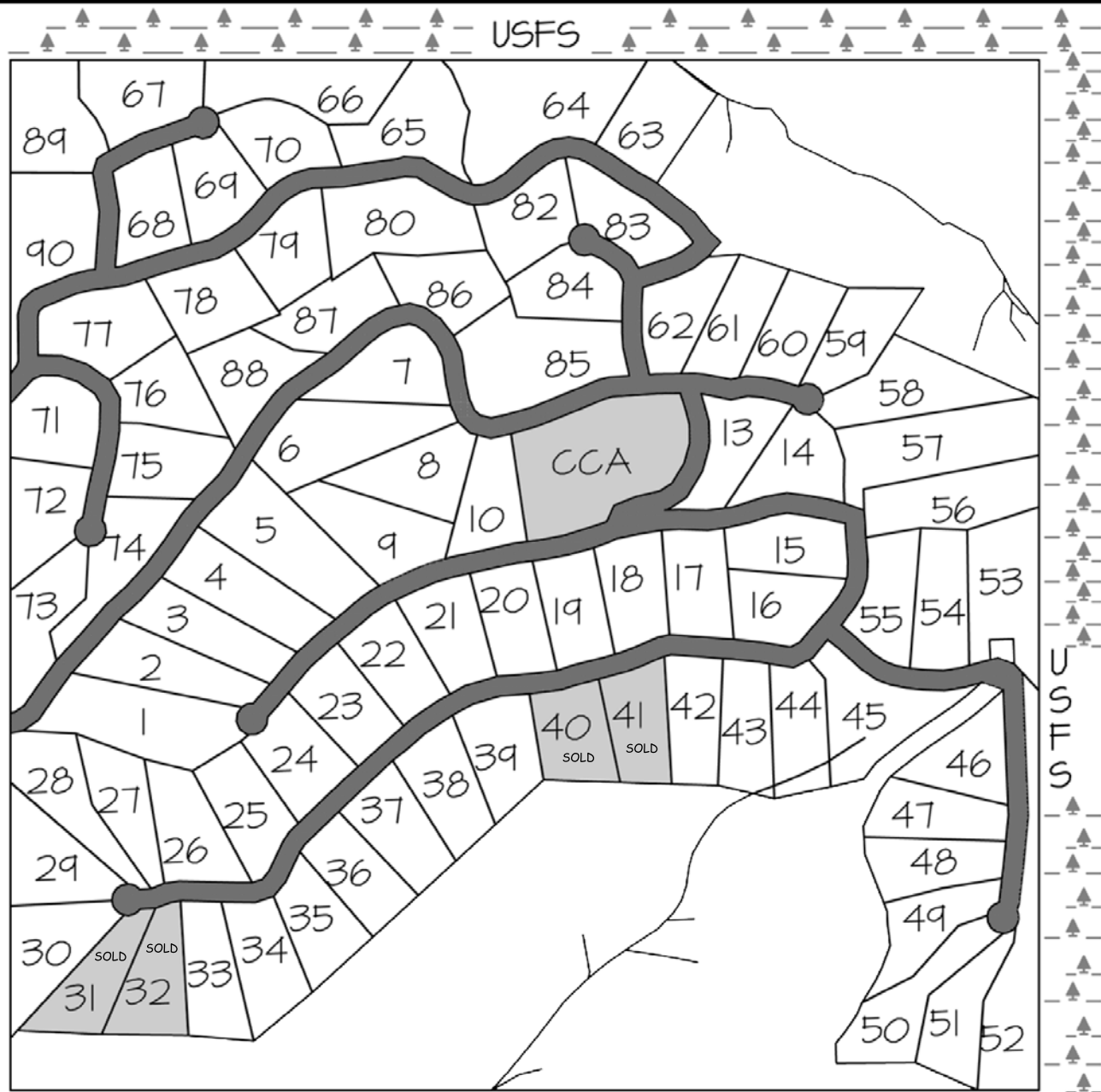

ROCKY KNOB ESTATES



Landtech
SERVICES, INC.
"Knowledge Through Experience"

**GREEN MOUNTAIN DEVELOPMENT
INQUIRES: 706-835-6489**

Price List & Lot Description

Lot #	Acreage	Price	Description
1	1.83	175,000	MV-GC
2	1.22	170,000	MV-GC
3	1.14	170,000	MV-GC
4	1.34	180,000	MV-GC
5	1.77	180,000	MV-GC
6	1.63	170,000	MV-GC
7	1.11	170,000	MV-GC
8	1.20	170,000	MV-GC
9	1.34	180,000	MV-GC
10	1.00	175,000	MV-GC
11	1.34	SOLD	
12	1.78	SOLD	
13	1.00	165,000	MV-GC
14	1.03	170,000	MV-GC
15	1.00	170,000	MV
16	1.00	200,000	RV-MV
17	1.03	200,000	MV-GC-RV
18	1.03	200,000	MV-GC-RV
19	1.01	200,000	MV-GC-RV
20	1.03	200,000	MV-GC-RV

MV=Mountain Views
 FS=Forest Service
 GC=Golf Course & Lake Views

Lot #	Acreage	Price	Description
21	1.05	200,000	MV-GC-RV
22	1.04	200,000	MV-GC-RV
23	1.04	200,000	MV-GC-RV
24	1.10	200,000	MV-GC-RV
25	1.10	200,000	MV-GC-RV
26	1.16	200,000	MV-GC-RV
27	1.00	200,000	MV-GC-RV
28	1.20	200,000	MV-GC-RV
29	1.16	200,000	MV-GC-RV
30	1.23	200,000	MV-CV-RV
31	1.04	SOLD	
32	1.08	SOLD	
33	1.09	220,000	MV-RV
34	1.11	220,000	MV-RV-WV
35	1.00	220,000	MV-RV-WV
36	1.02	220,000	MV-RV-WV
37	1.10	220,000	MV-RV-WV
38	1.12	220,000	MV-RV-WV
39	1.11	SOLD	
40	1.04	SOLD	

RV=Ridge Lots CR=Creek
 CV=City Views
 WV=Wilderness View

Price List & Lot Description

Lot #	Acreage	Price	Description
41	1.03	SOLD	
42	1.01	220,000	MV-RV-WV
43	1.02	220,000	MV-RV
44	1.07	220,000	MV-RV
45	1.49	225,000	MV-RV-WV
46	1.00	200,000	RV-MV
47	1.01	250,000	MV-RV-CV
48	1.03	250,000	MV-RV-CV
49	1.01	250,000	MV-RV-CV
50	1.24	225,000	MV-RV-WV
51	1.08	225,000	MV-RV-WV
52	1.25	225,000	MV-RV-WV-FS
53	1.00	165,000	MV-RV-WV-FS
54	1.12	170,000	MV-RV-WV
55	1.05	170,000	MV-RV-WV
56	1.22	170,000	MV-WV-FS
57	1.66	170,000	MV-WV-FS
58	1.43	170,000	MV-WV-FS
59	1.00	165,000	MV-WV
60	1.00	165,000	MV-WV
61	1.00	165,000	MV-WV
62	1.00	165,000	MV-WV
63	1.21	180,000	MV-WV-FS-CR
64	2.14	180,000	MV-WV-FS
65	1.44	170,000	MV-WV-FS

Lot #	Acreage	Price	Description
66	1.39	170,000	MV-WV-FS
67	1.23	170,000	MV-WV-FS
68	1.02	150,000	MV-WV
69	1.01	165,000	MV-WV
70	1.03	170,000	MV-WV
71	1.00	165,000	MV-GC
72	1.01	165,000	MV-GC
73	1.04	165,000	MV-GC
74	1.15	165,000	MV-GC
75	1.12	165,000	MV-GC
76	1.00	165,000	MV-GC
77	1.35	165,000	MV-GC
78	1.18	165,000	MV-GC
79	1.07	165,000	MV-GC
80	1.64	170,000	MV-GC
81	1.00	SOLD	
82	1.10	170,000	MV-GC
83	1.00	170,000	MV-WV
84	1.00	170,000	MV-GC
85	1.99	175,000	MV-GC
86	1.05	170,000	MV-WV
87	1.04	170,000	MV-GC
88	1.13	170,000	MV-GC
89	1.22	150,000	MV-WV-FS
90	1.31	170,000	MV-WV

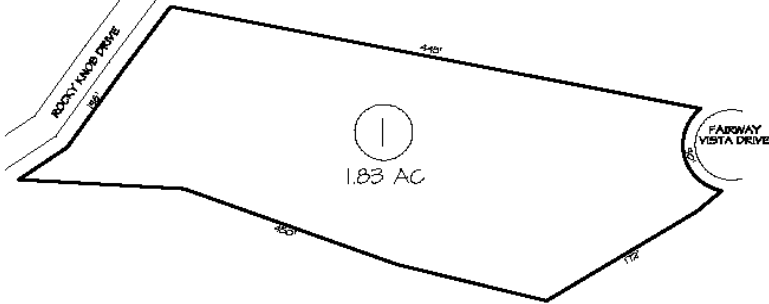
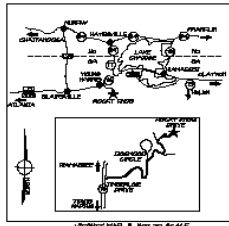
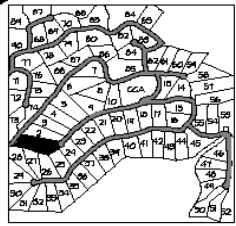

ROCKY KNOB
ESTATES

GREEN MOUNTAIN DEVELOPMENT
INQUIRES: 706-885-6488

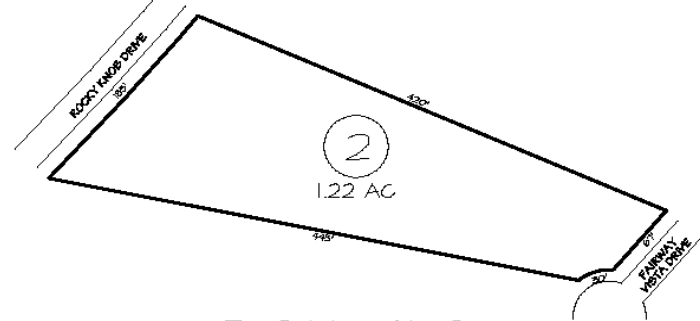
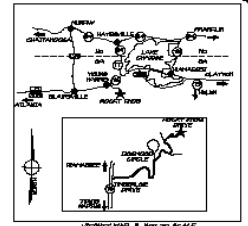
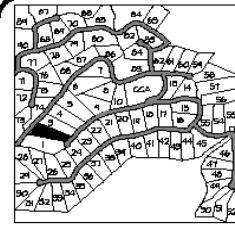

ROCKY KNOB
ESTATES

GREEN MOUNTAIN DEVELOPMENT
INQUIRES: 706-885-6488

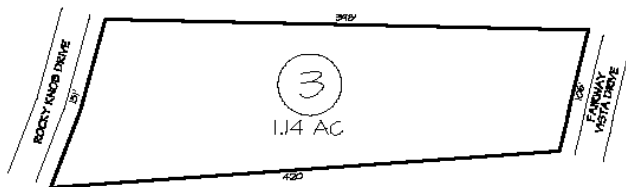
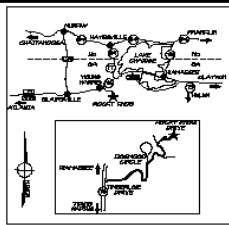
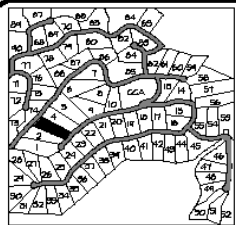

ROCKY KNOB
ESTATES

GREEN MOUNTAIN DEVELOPMENT
INQUIRES: 706-885-6488

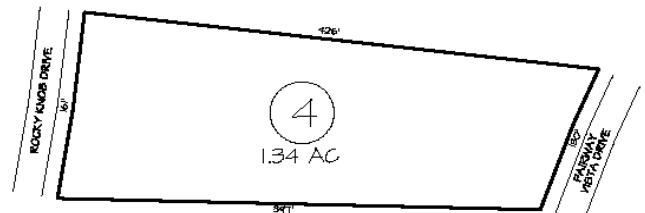
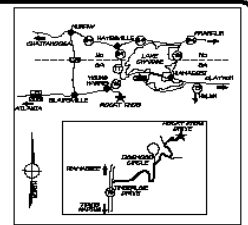
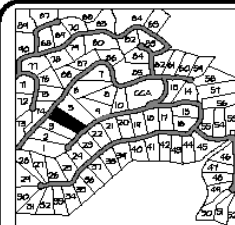

ROCKY KNOB
ESTATES

GREEN MOUNTAIN DEVELOPMENT
INQUIRES: 706-885-6488

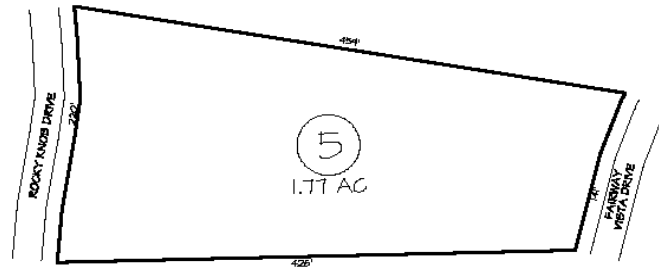
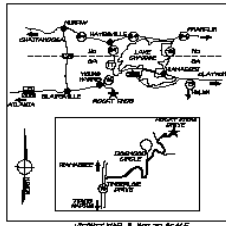
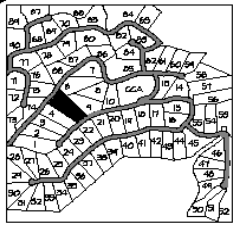

ROCKY KNOB
ESTATES

GREEN MOUNTAIN DEVELOPMENT
INQUIRES: 706-885-6488

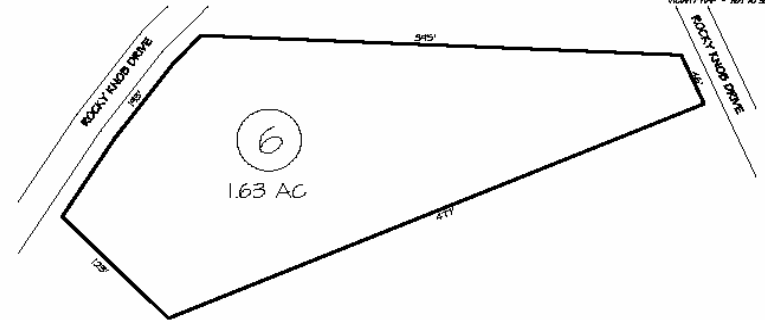
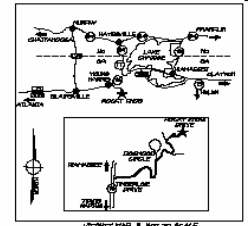
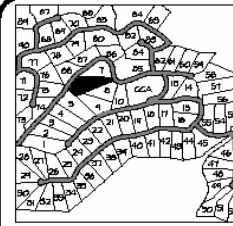

ROCKY KNOB
ESTATES

GREEN MOUNTAIN DEVELOPMENT
INQUIRES: 706-885-6488

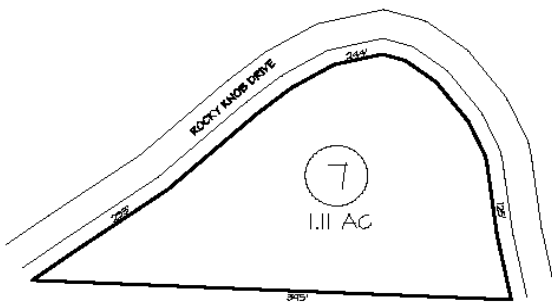
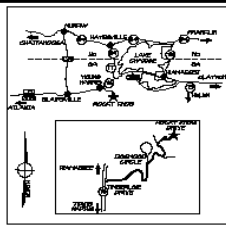
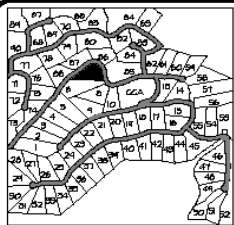

ROCKY KNOB
ESTATES

GREEN MOUNTAIN DEVELOPMENT
INQUIRES: 706-885-6488

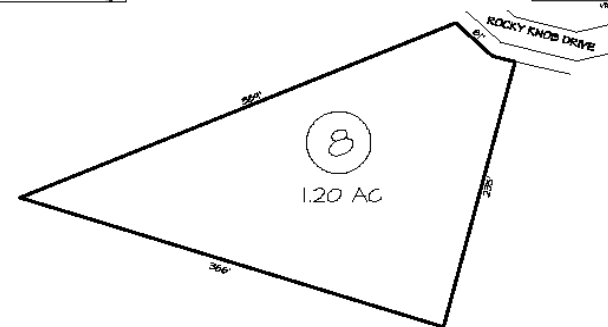
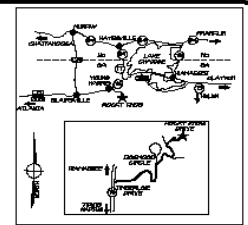
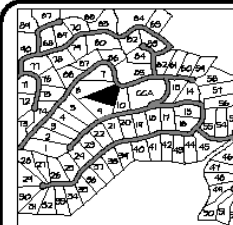

ROCKY KNOB
ESTATES

GREEN MOUNTAIN DEVELOPMENT
INQUIRES: 706-885-6488

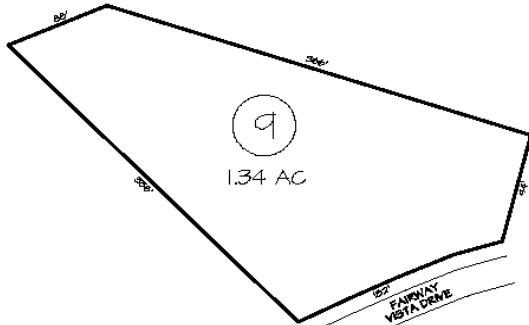
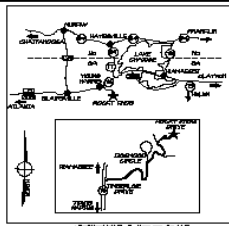
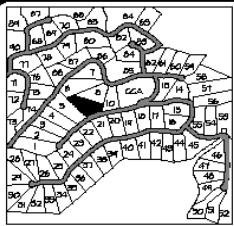

ROCKY KNOB
ESTATES



GREEN MOUNTAIN DEVELOPMENT
INQUIRES: 706-885-6488

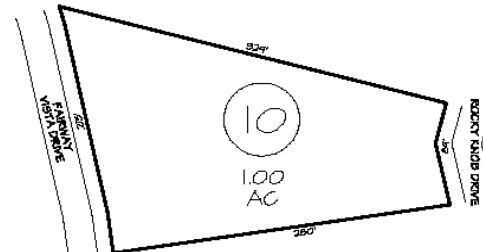
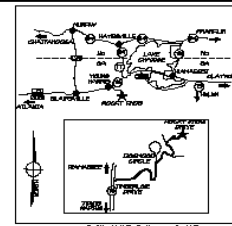
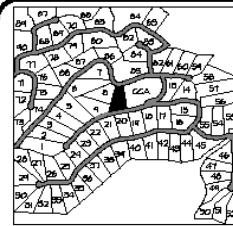

ROCKY KNOB
ESTATES



GREEN MOUNTAIN DEVELOPMENT
INQUIRES: 706-885-6488

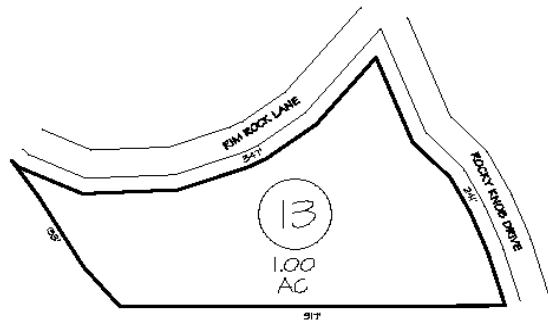
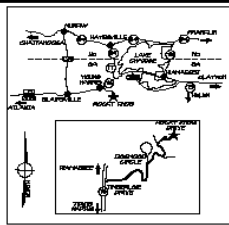
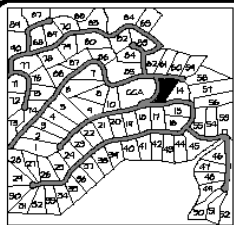

ROCKY KNOB
ESTATES



GREEN MOUNTAIN DEVELOPMENT
INQUIRES: 706-885-6488

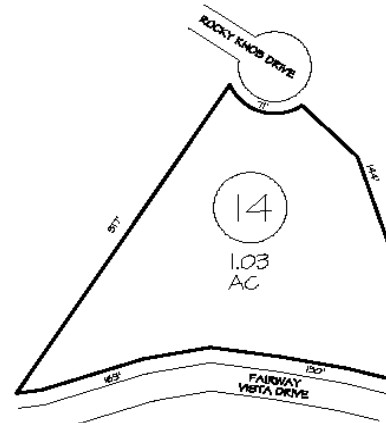
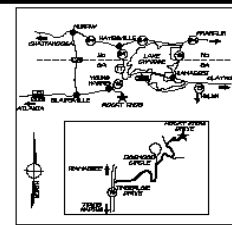
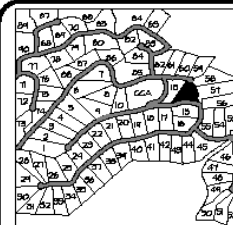

ROCKY KNOB
ESTATES



GREEN MOUNTAIN DEVELOPMENT
INQUIRES: 706-885-6488

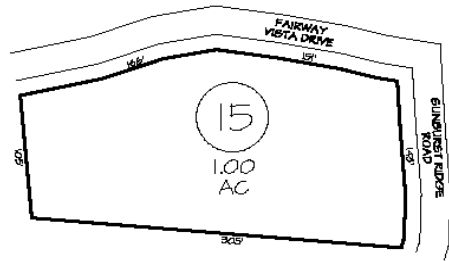
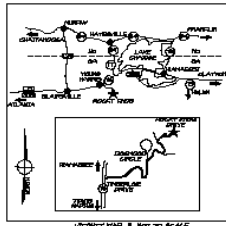
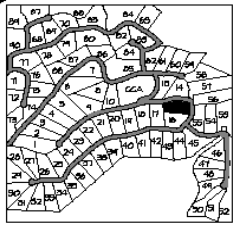

ROCKY KNOB
ESTATES



GREEN MOUNTAIN DEVELOPMENT
INQUIRES: 706-885-6488

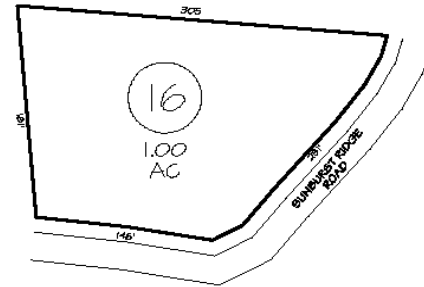
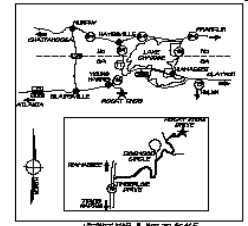
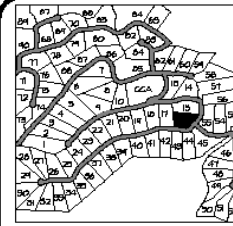

ROCKY KNOB
ESTATES



GREEN MOUNTAIN DEVELOPMENT
INQUIRES: 706-885-6488

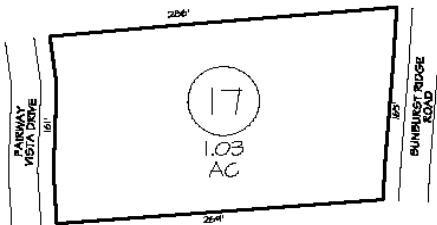
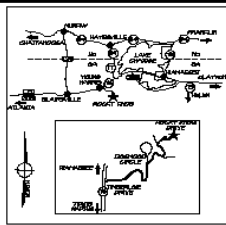
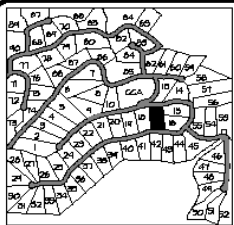

ROCKY KNOB
ESTATES



GREEN MOUNTAIN DEVELOPMENT
INQUIRES: 706-885-6488

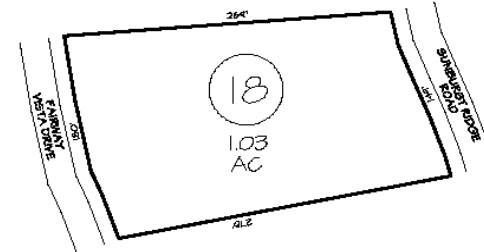
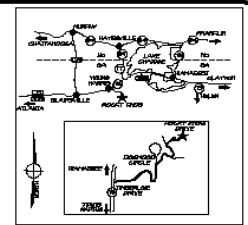
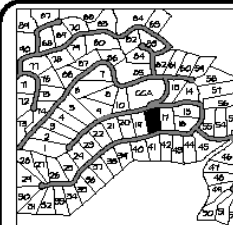

ROCKY KNOB
ESTATES



GREEN MOUNTAIN DEVELOPMENT
INQUIRES: 706-885-6488

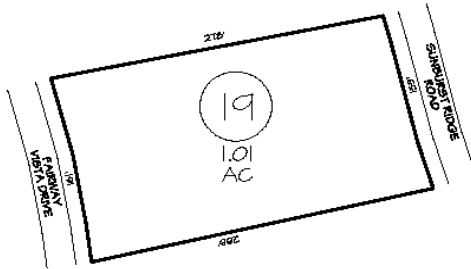
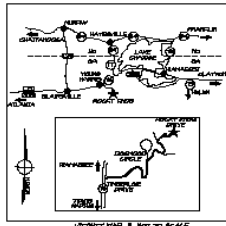
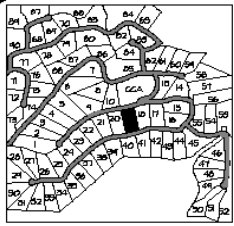

ROCKY KNOB
ESTATES

GREEN MOUNTAIN DEVELOPMENT
INQUIRES: 706-885-6488

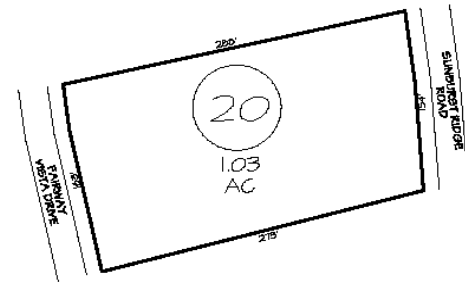
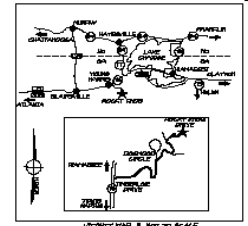
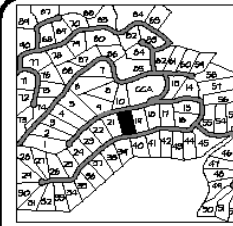

ROCKY KNOB
ESTATES

GREEN MOUNTAIN DEVELOPMENT
INQUIRES: 706-885-6488

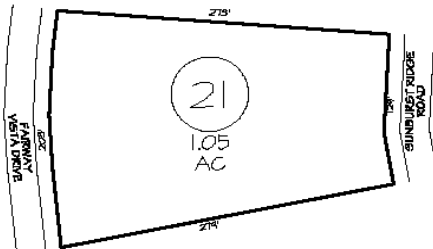
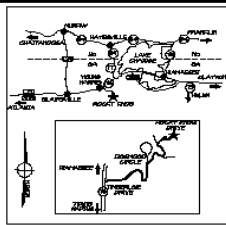
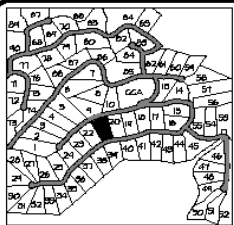

ROCKY KNOB
ESTATES

GREEN MOUNTAIN DEVELOPMENT
INQUIRES: 706-885-6488

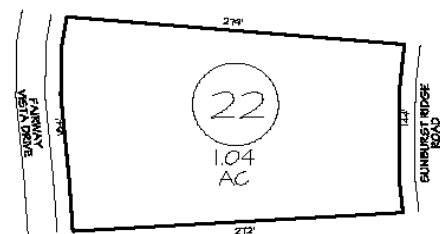
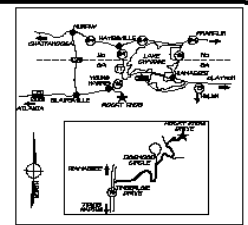
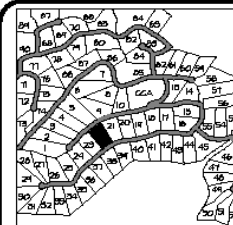

ROCKY KNOB
ESTATES

GREEN MOUNTAIN DEVELOPMENT
INQUIRES: 706-885-6488

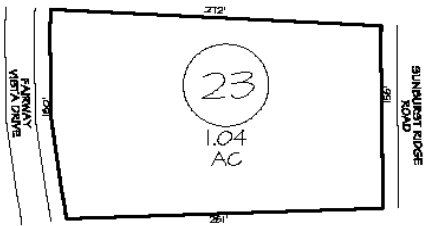
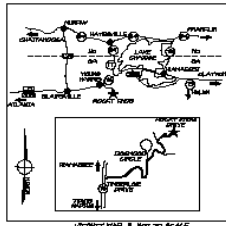
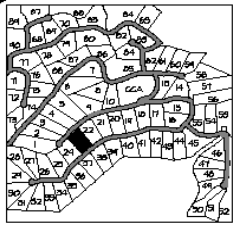

ROCKY KNOB
ESTATES

GREEN MOUNTAIN DEVELOPMENT
INQUIRES: 706-885-6489

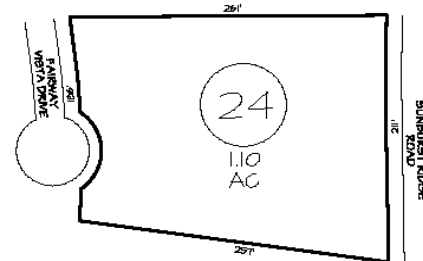
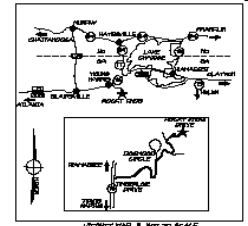
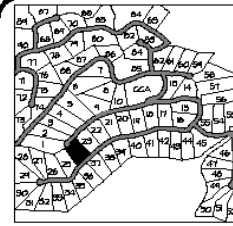

ROCKY KNOB
ESTATES

GREEN MOUNTAIN DEVELOPMENT
INQUIRES: 706-885-6489

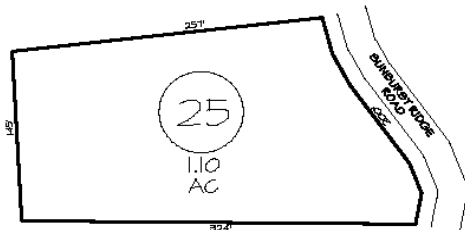
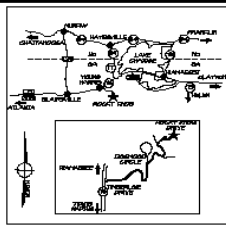
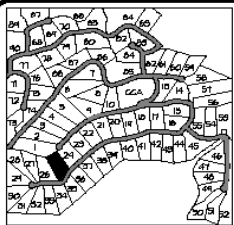

ROCKY KNOB
ESTATES

GREEN MOUNTAIN DEVELOPMENT
INQUIRES: 706-885-6489

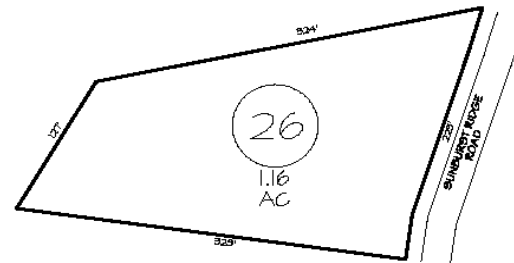
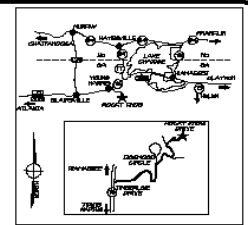
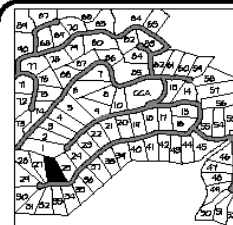

ROCKY KNOB
ESTATES

GREEN MOUNTAIN DEVELOPMENT
INQUIRES: 706-885-6489

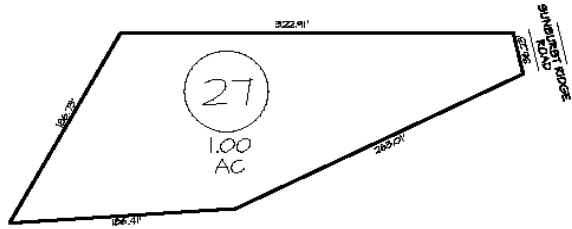
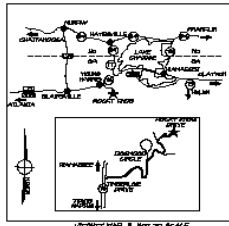
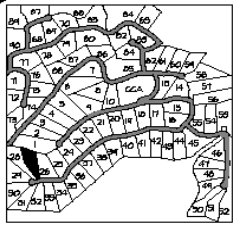

ROCKY KNOB
ESTATES

GREEN MOUNTAIN DEVELOPMENT
INQUIRES: 706-888-6488

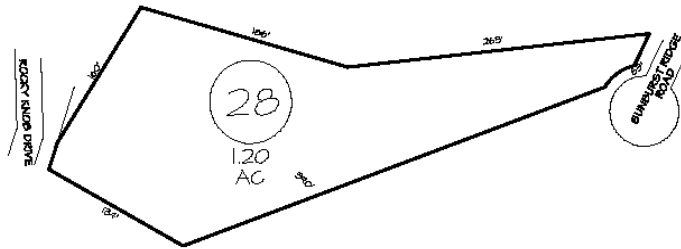
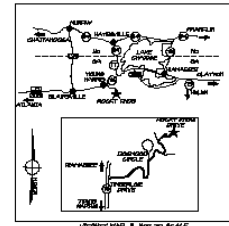
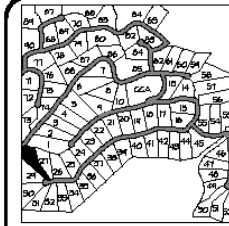

ROCKY KNOB
ESTATES

GREEN MOUNTAIN DEVELOPMENT
INQUIRES: 706-888-6488

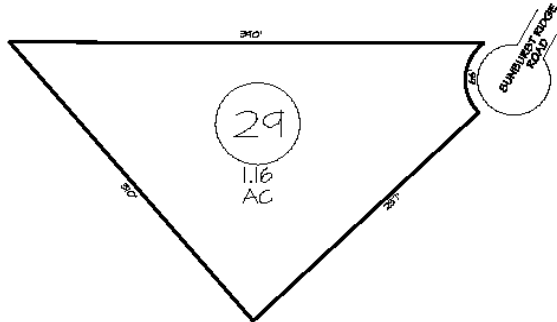
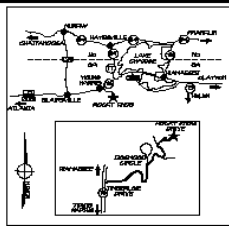

ROCKY KNOB
ESTATES

GREEN MOUNTAIN DEVELOPMENT
INQUIRES: 706-888-6488

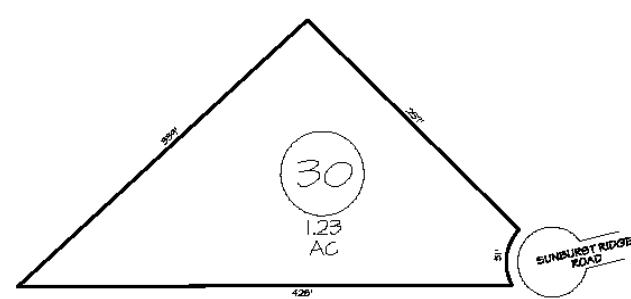
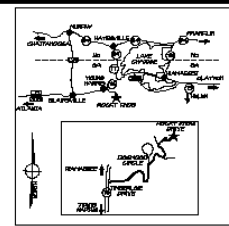
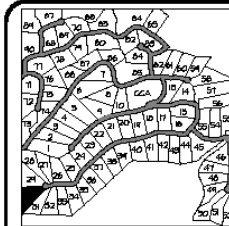

ROCKY KNOB
ESTATES

GREEN MOUNTAIN DEVELOPMENT
INQUIRES: 706-888-6488

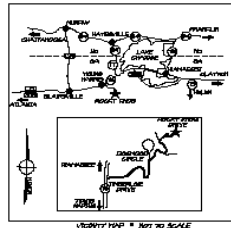
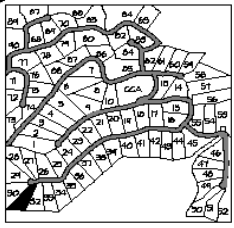

VELOCITY MAP * NOT TO SCALE

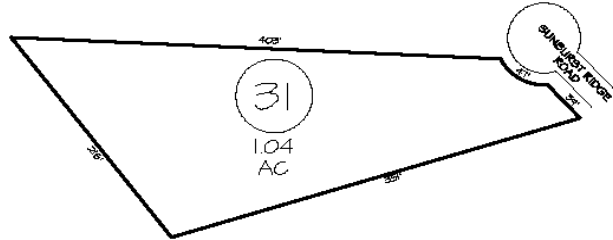

ROCKY KNOB
ESTATES

GREEN MOUNTAIN DEVELOPMENT
INQUIRES: 706-885-6488

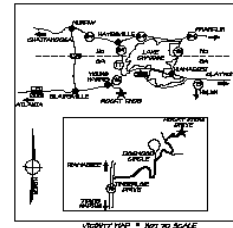
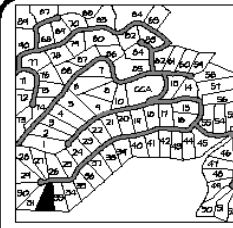

VELOCITY MAP * NOT TO SCALE

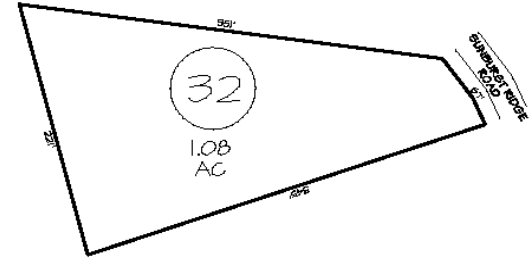

ROCKY KNOB
ESTATES

GREEN MOUNTAIN DEVELOPMENT
INQUIRES: 706-885-6488

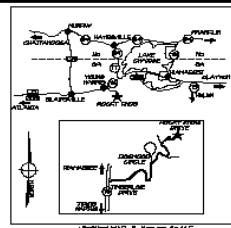
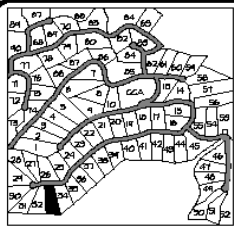

VELOCITY MAP * NOT TO SCALE

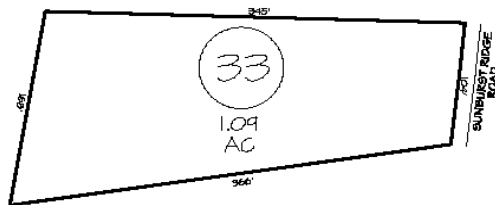

ROCKY KNOB
ESTATES

GREEN MOUNTAIN DEVELOPMENT
INQUIRES: 706-885-6488

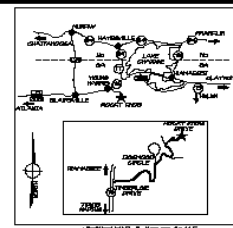
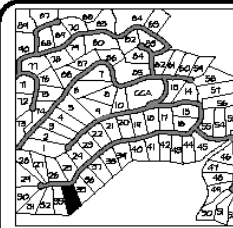

VELOCITY MAP * NOT TO SCALE

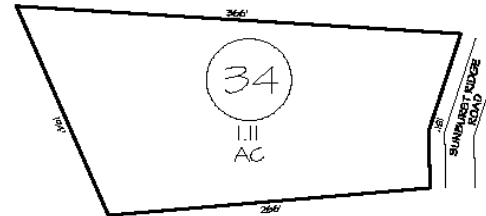

ROCKY KNOB
ESTATES

GREEN MOUNTAIN DEVELOPMENT
INQUIRES: 706-885-6488

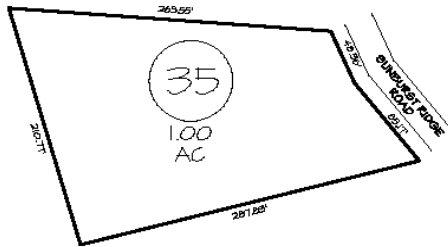
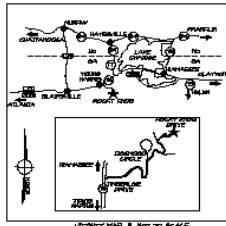
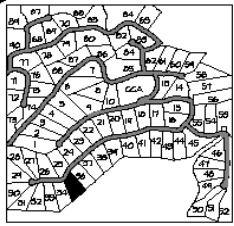

ROCKY KNOB
ESTATES

GREEN MOUNTAIN DEVELOPMENT
INQUIRES: 706-885-6488

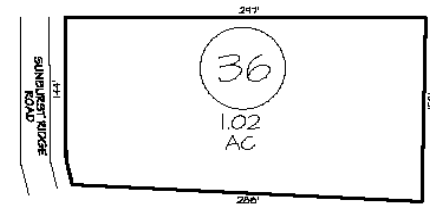
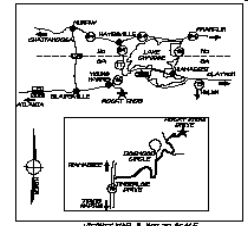
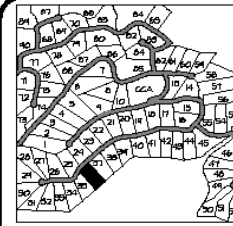

ROCKY KNOB
ESTATES

GREEN MOUNTAIN DEVELOPMENT
INQUIRES: 706-885-6488

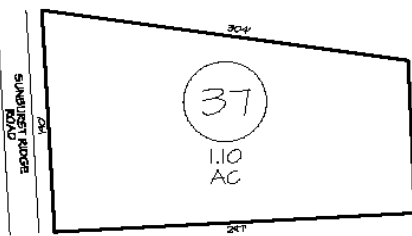
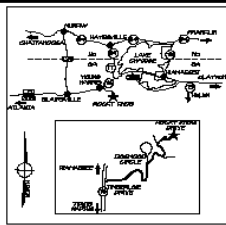
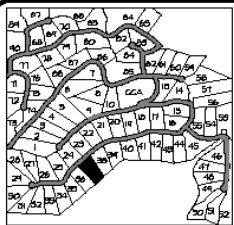

ROCKY KNOB
ESTATES

GREEN MOUNTAIN DEVELOPMENT
INQUIRES: 706-885-6488

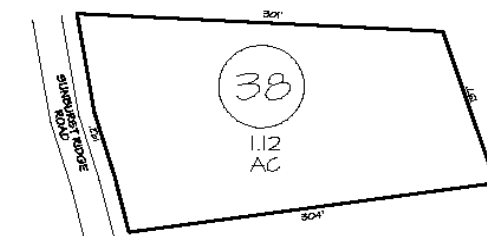
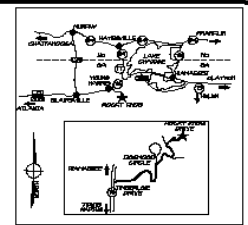
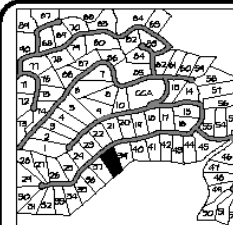

ROCKY KNOB
ESTATES

GREEN MOUNTAIN DEVELOPMENT
INQUIRES: 706-885-6488

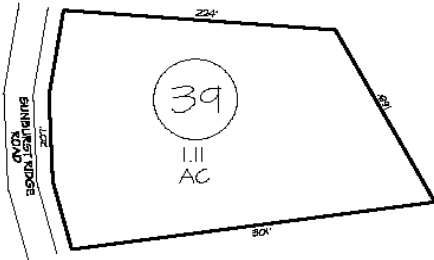
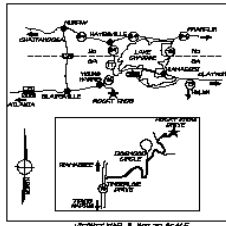
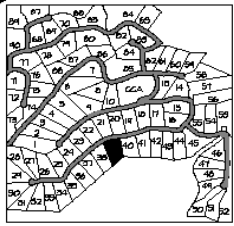

ROCKY KNOB
ESTATES

GREEN MOUNTAIN DEVELOPMENT
INQUIRES: 706-885-6488

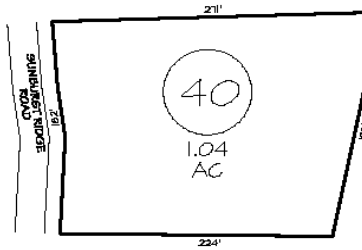
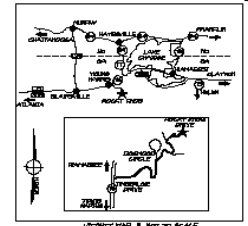
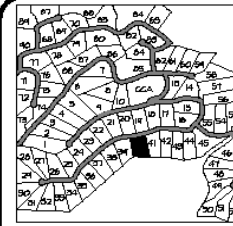

ROCKY KNOB
ESTATES

GREEN MOUNTAIN DEVELOPMENT
INQUIRES: 706-885-6488

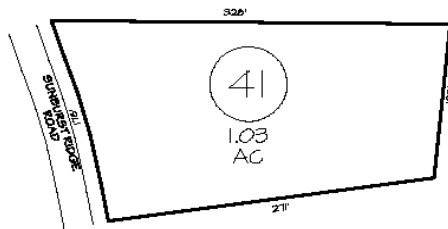
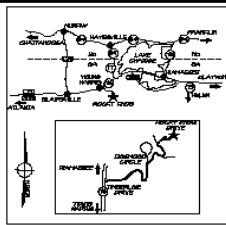
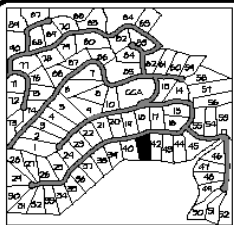

ROCKY KNOB
ESTATES

GREEN MOUNTAIN DEVELOPMENT
INQUIRES: 706-885-6488

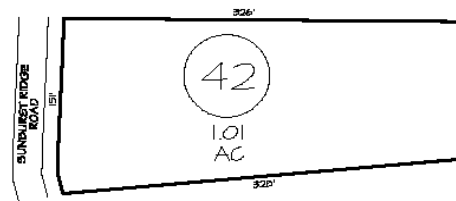
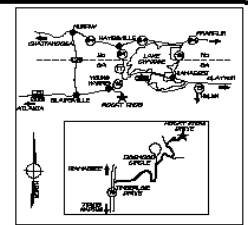
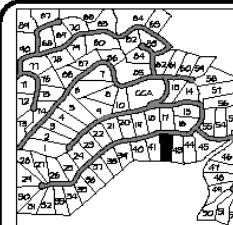

ROCKY KNOB
ESTATES

GREEN MOUNTAIN DEVELOPMENT
INQUIRES: 706-885-6488

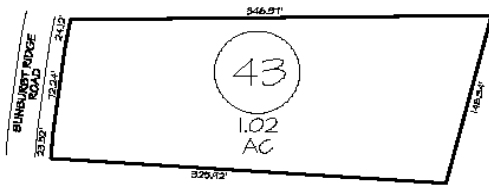
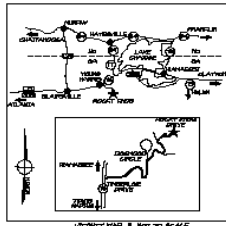
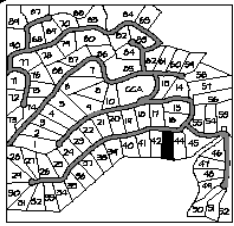

ROCKY KNOB
ESTATES



GREEN MOUNTAIN DEVELOPMENT
INQUIRES: 706-885-6488

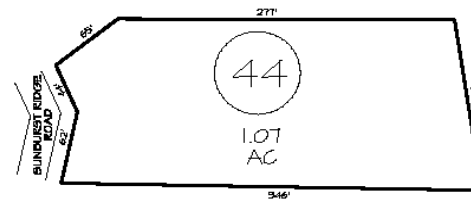
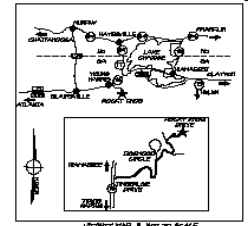
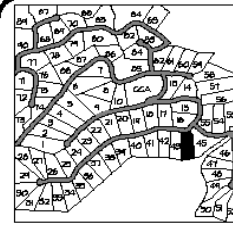

ROCKY KNOB
ESTATES



GREEN MOUNTAIN DEVELOPMENT
INQUIRES: 706-885-6488

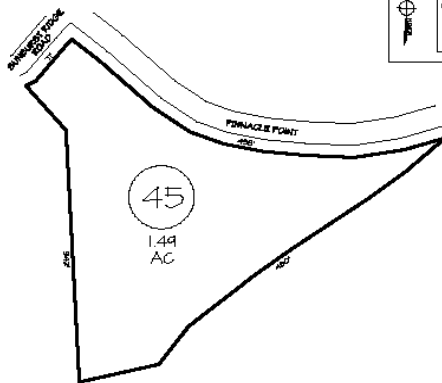
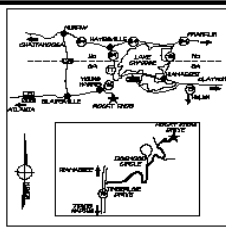
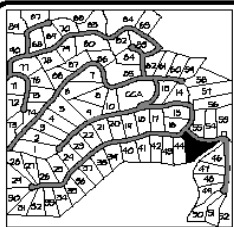

ROCKY KNOB
ESTATES



GREEN MOUNTAIN DEVELOPMENT
INQUIRES: 706-885-6488

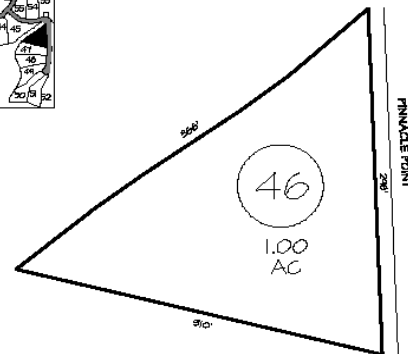
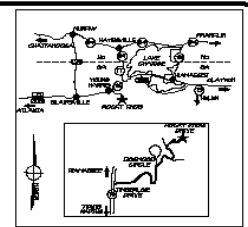
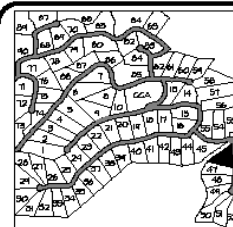

ROCKY KNOB
ESTATES



GREEN MOUNTAIN DEVELOPMENT
INQUIRES: 706-885-6488

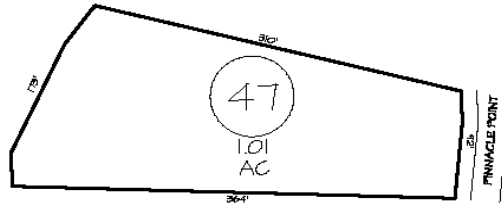
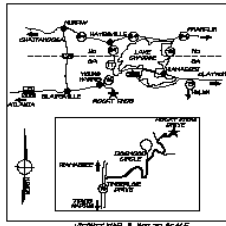
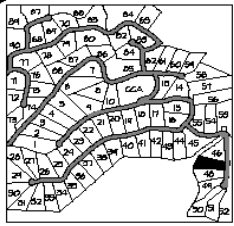

ROCKY KNOB
ESTATES

GREEN MOUNTAIN DEVELOPMENT
INQUIRES: 706-885-6489

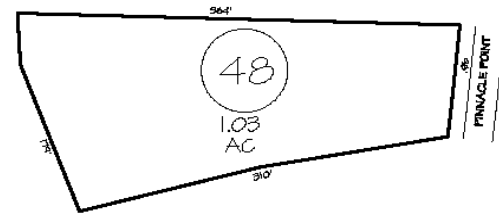
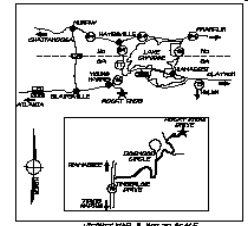
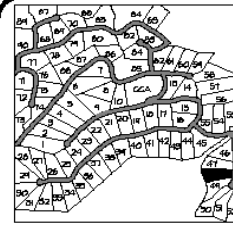

ROCKY KNOB
ESTATES

GREEN MOUNTAIN DEVELOPMENT
INQUIRES: 706-885-6489

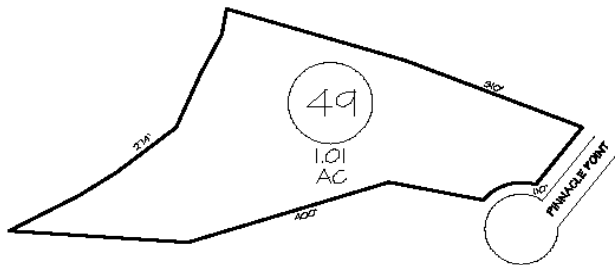
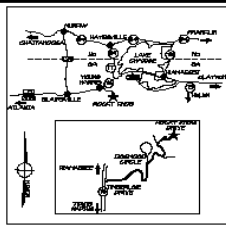
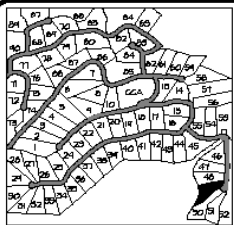

ROCKY KNOB
ESTATES

GREEN MOUNTAIN DEVELOPMENT
INQUIRES: 706-885-6489

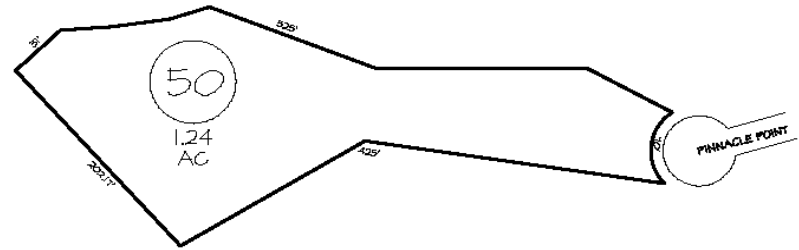
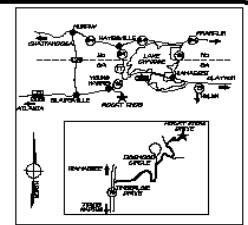
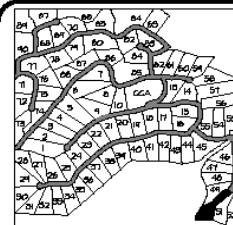

ROCKY KNOB
ESTATES

GREEN MOUNTAIN DEVELOPMENT
INQUIRES: 706-885-6489

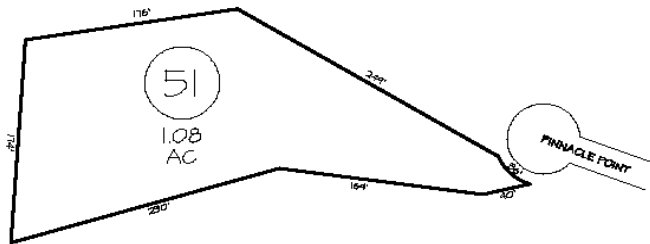
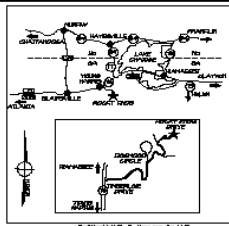
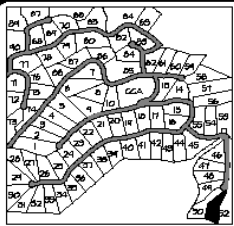

ROCKY KNOB
ESTATES

GREEN MOUNTAIN DEVELOPMENT
INQUIRES: 706-885-6488

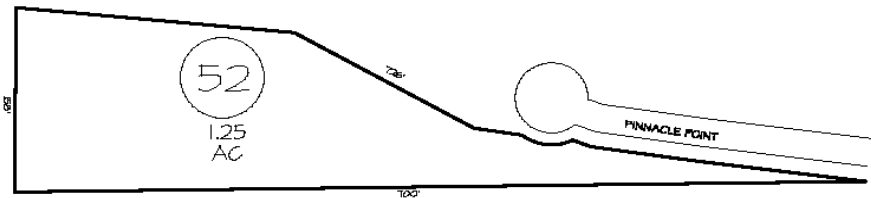
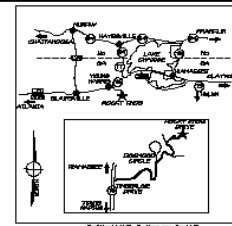
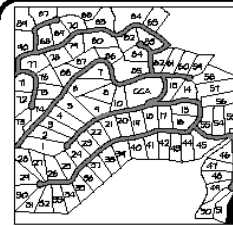

ROCKY KNOB
ESTATES

GREEN MOUNTAIN DEVELOPMENT
INQUIRES: 706-885-6488

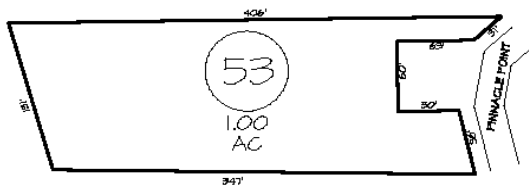
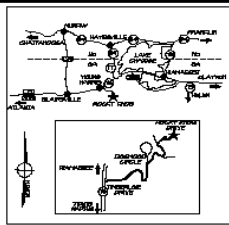
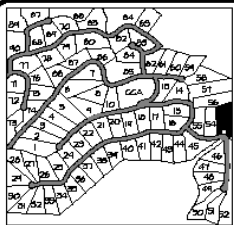

ROCKY KNOB
ESTATES

GREEN MOUNTAIN DEVELOPMENT
INQUIRES: 706-885-6488

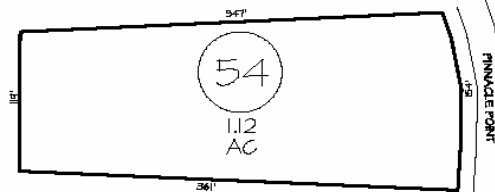
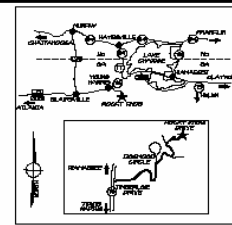
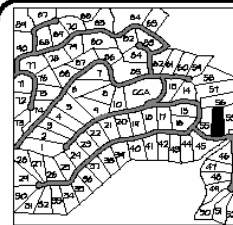

ROCKY KNOB
ESTATES

GREEN MOUNTAIN DEVELOPMENT
INQUIRES: 706-885-6488

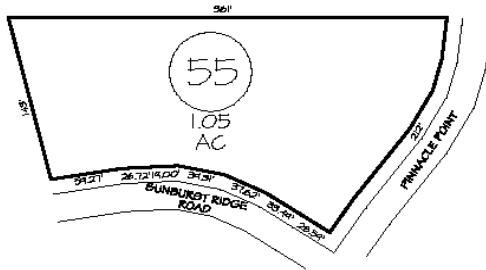
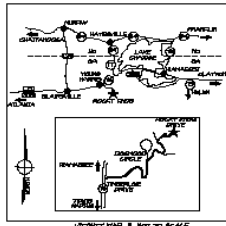
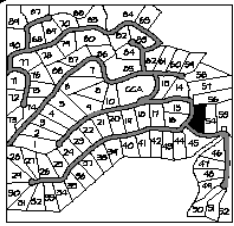

ROCKY KNOB
ESTATES

GREEN MOUNTAIN DEVELOPMENT
INQUIRES: 706-885-6488

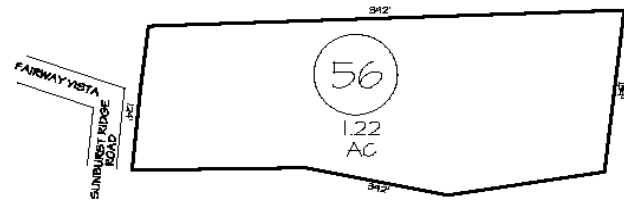
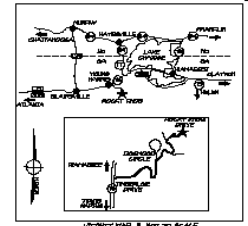
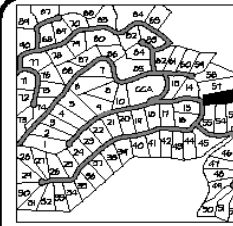

ROCKY KNOB
ESTATES

GREEN MOUNTAIN DEVELOPMENT
INQUIRES: 706-885-6488

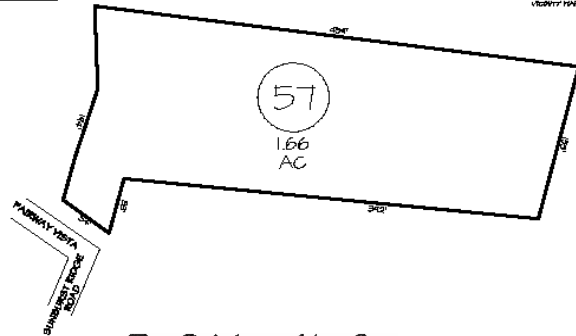
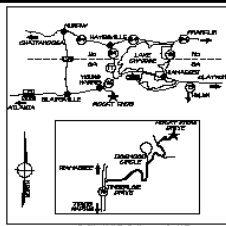
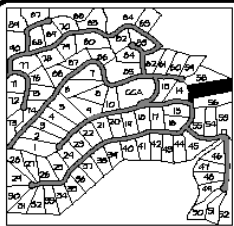

ROCKY KNOB
ESTATES

GREEN MOUNTAIN DEVELOPMENT
INQUIRES: 706-885-6488

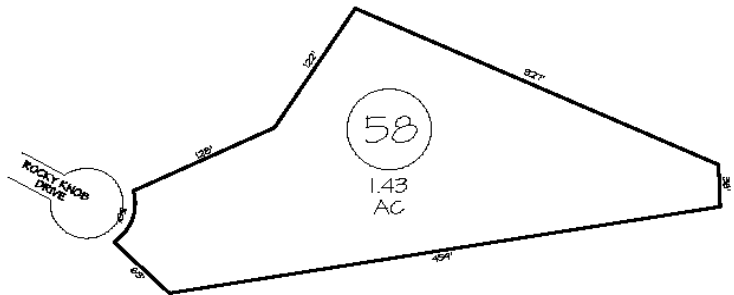
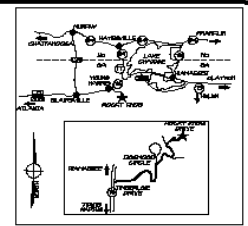
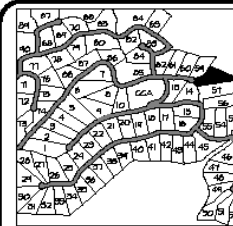

ROCKY KNOB
ESTATES

GREEN MOUNTAIN DEVELOPMENT
INQUIRES: 706-885-6488

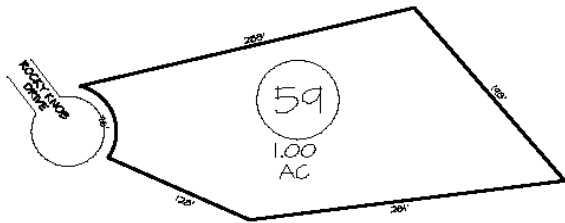
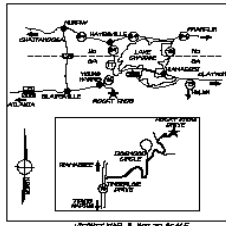
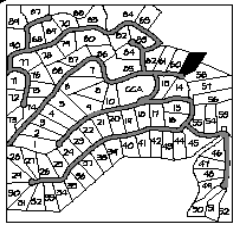

ROCKY KNOB
ESTATES



GREEN MOUNTAIN DEVELOPMENT
INQUIRES: 706-885-6489

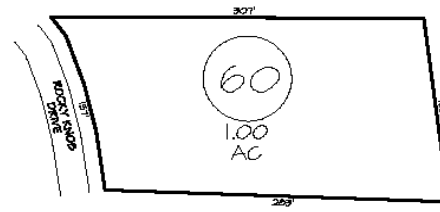
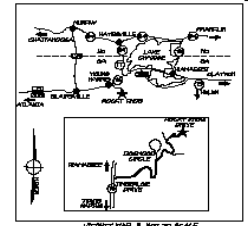
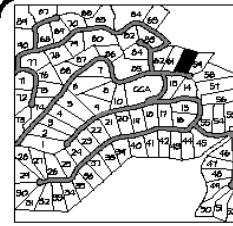

ROCKY KNOB
ESTATES



GREEN MOUNTAIN DEVELOPMENT
INQUIRES: 706-885-6489

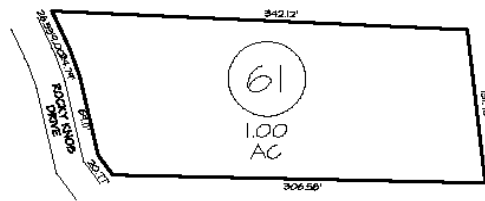
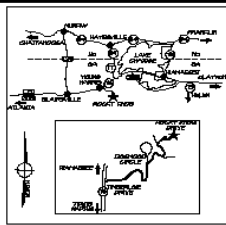
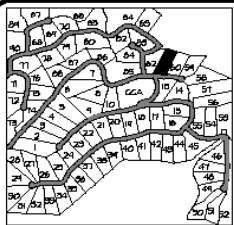

ROCKY KNOB
ESTATES



GREEN MOUNTAIN DEVELOPMENT
INQUIRES: 706-885-6489

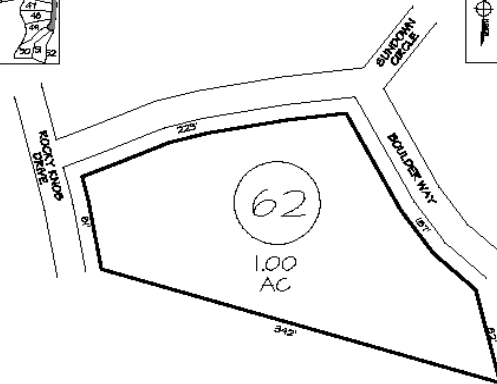
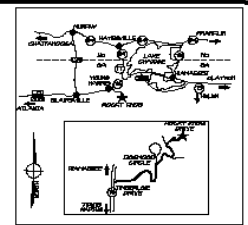
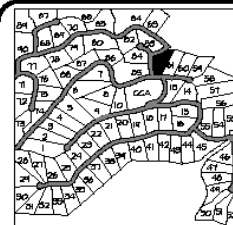

ROCKY KNOB
ESTATES



GREEN MOUNTAIN DEVELOPMENT
INQUIRES: 706-885-6489

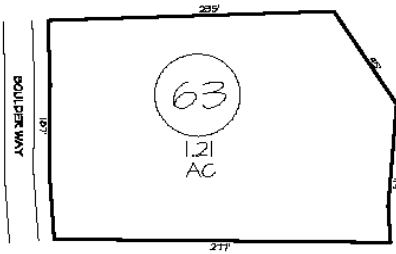
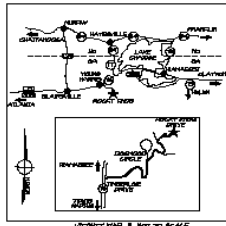
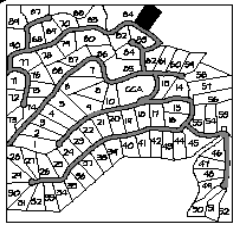

ROCKY KNOB
ESTATES



GREEN MOUNTAIN DEVELOPMENT
INQUIRES: 706-885-6488

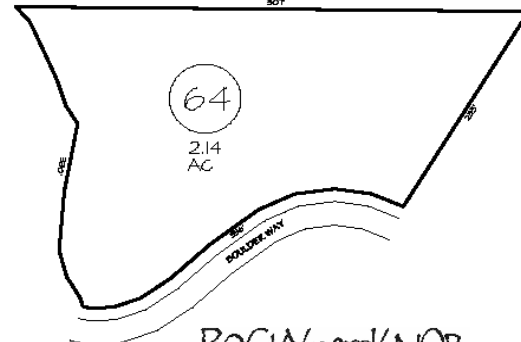
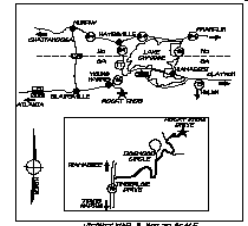
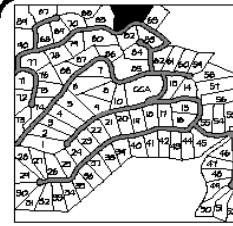

ROCKY KNOB
ESTATES



GREEN MOUNTAIN DEVELOPMENT
INQUIRES: 706-885-6488

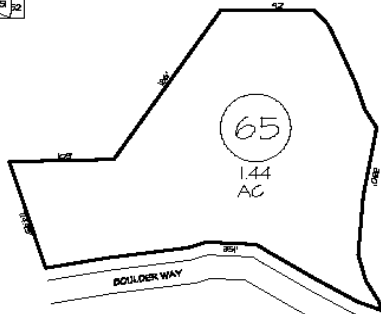
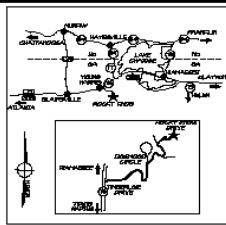
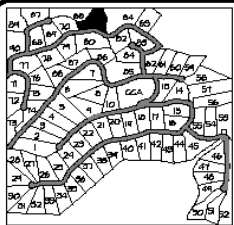

ROCKY KNOB
ESTATES



GREEN MOUNTAIN DEVELOPMENT
INQUIRES: 706-885-6488

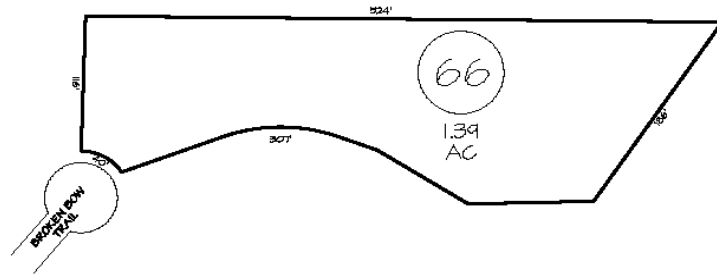
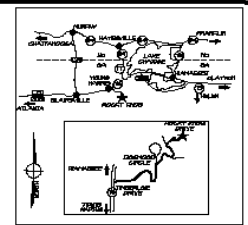
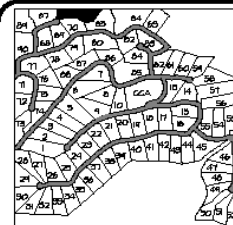

ROCKY KNOB
ESTATES



GREEN MOUNTAIN DEVELOPMENT
INQUIRES: 706-885-6488

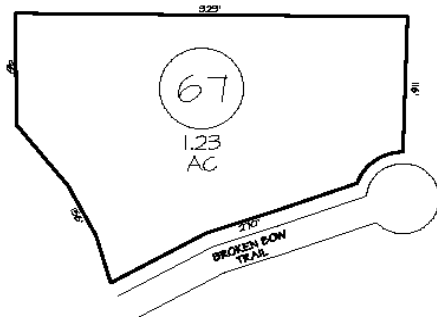
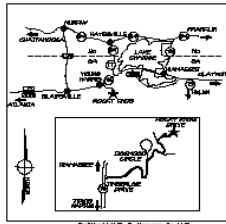
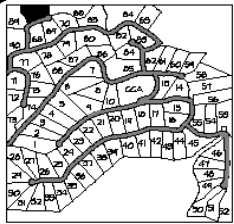

ROCKY KNOB
ESTATES



GREEN MOUNTAIN DEVELOPMENT
INQUIRES: 706-885-6489

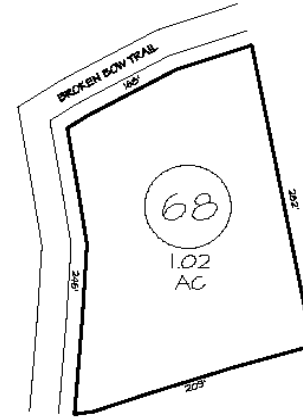
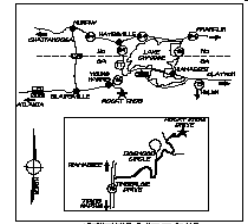
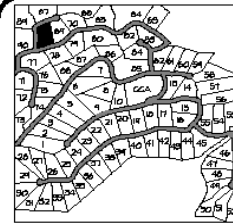

ROCKY KNOB
ESTATES



GREEN MOUNTAIN DEVELOPMENT
INQUIRES: 706-885-6489

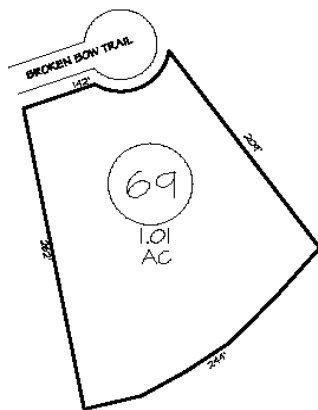
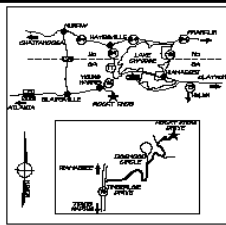
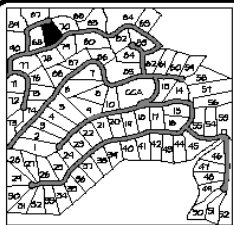

ROCKY KNOB
ESTATES



GREEN MOUNTAIN DEVELOPMENT
INQUIRES: 706-885-6489

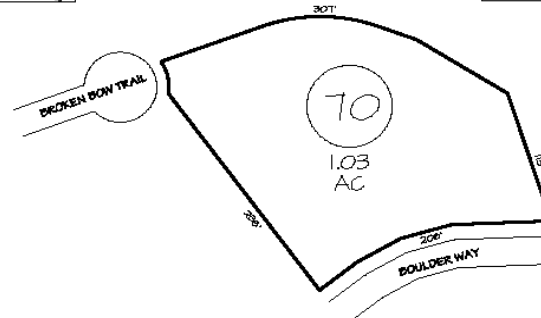
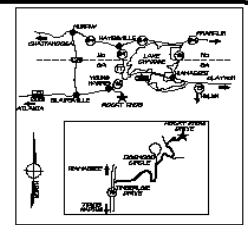
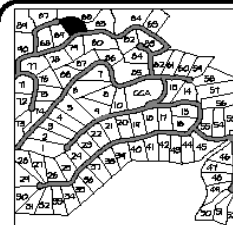

ROCKY KNOB
ESTATES



GREEN MOUNTAIN DEVELOPMENT
INQUIRES: 706-885-6489

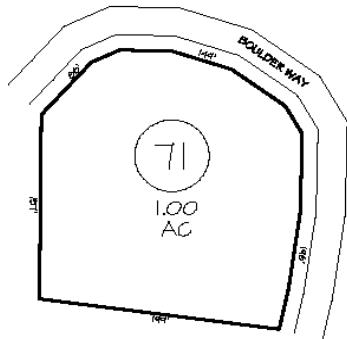
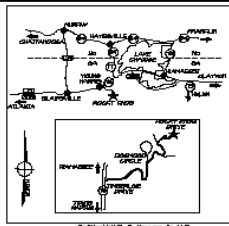
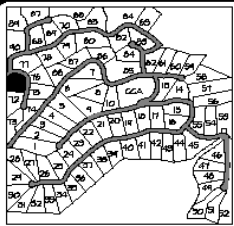

ROCKY KNOB
ESTATES



GREEN MOUNTAIN DEVELOPMENT
INQUIRES: 706-885-6489

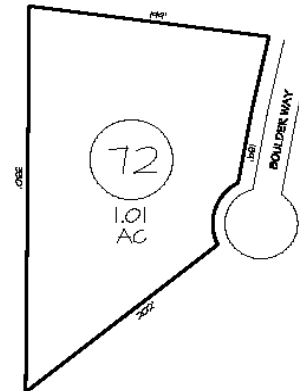
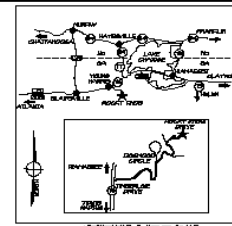
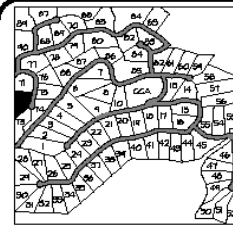

ROCKY KNOB
ESTATES



GREEN MOUNTAIN DEVELOPMENT
INQUIRES: 706-885-6489

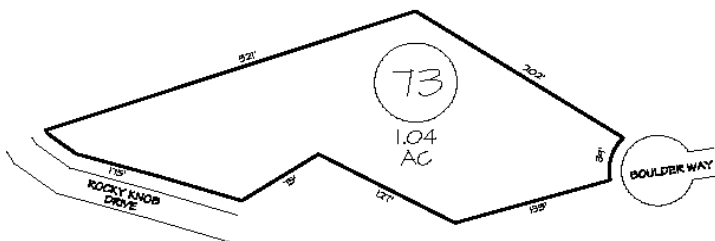
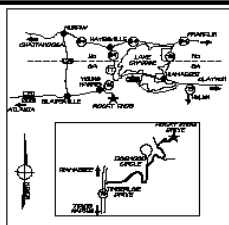
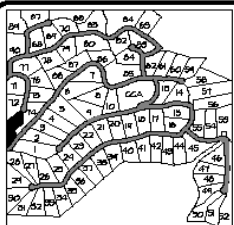

ROCKY KNOB
ESTATES



GREEN MOUNTAIN DEVELOPMENT
INQUIRES: 706-885-6489

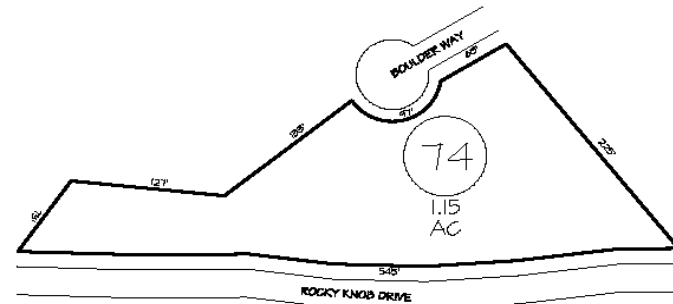
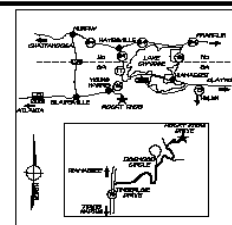
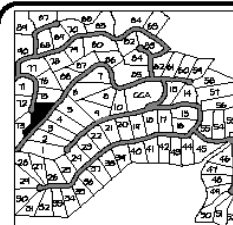

ROCKY KNOB
ESTATES



GREEN MOUNTAIN DEVELOPMENT
INQUIRES: 706-885-6489

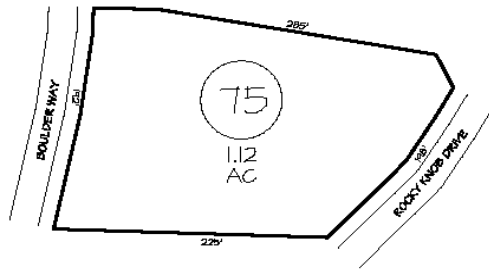
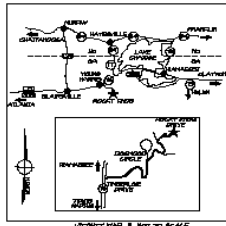
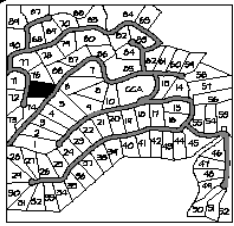

ROCKY KNOB
ESTATES

GREEN MOUNTAIN DEVELOPMENT
INQUIRES: 706-885-6488

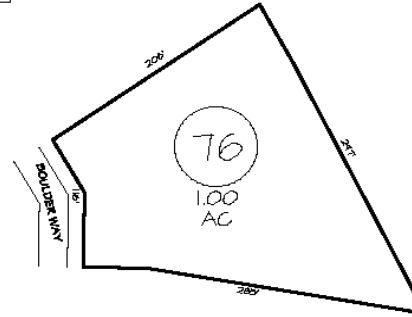
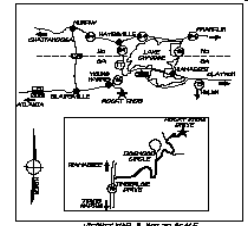
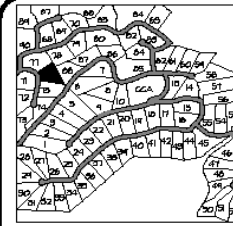

ROCKY KNOB
ESTATES

GREEN MOUNTAIN DEVELOPMENT
INQUIRES: 706-885-6488

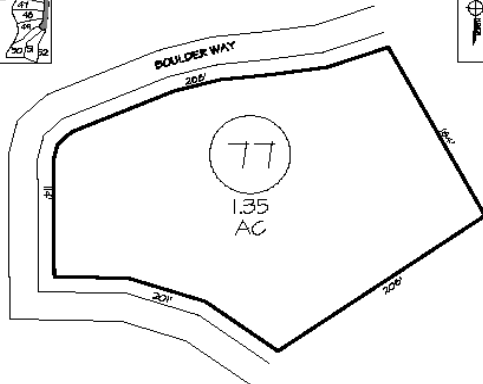
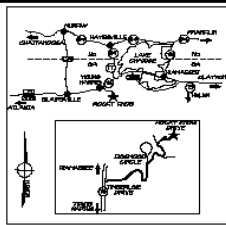
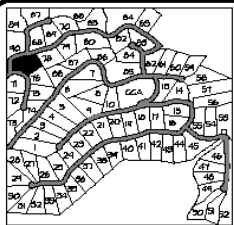

ROCKY KNOB
ESTATES

GREEN MOUNTAIN DEVELOPMENT
INQUIRES: 706-885-6488

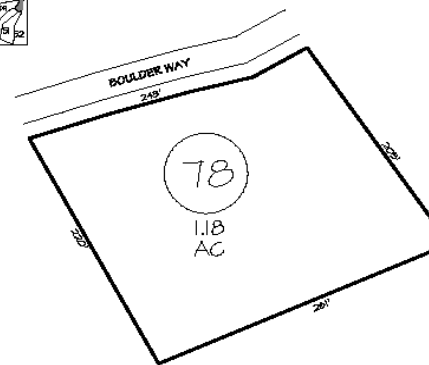
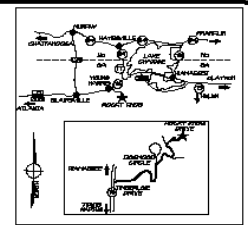
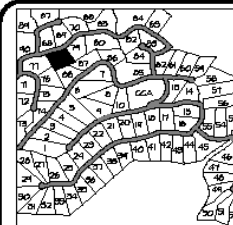

ROCKY KNOB
ESTATES

GREEN MOUNTAIN DEVELOPMENT
INQUIRES: 706-885-6488

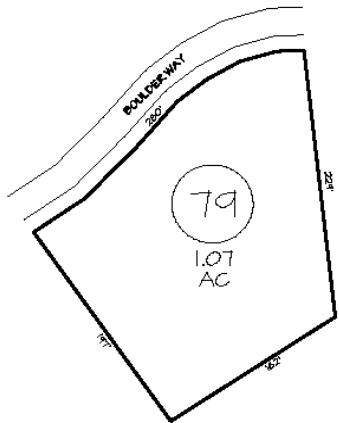
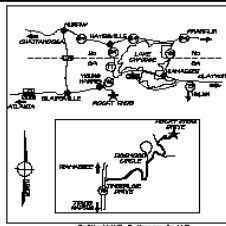
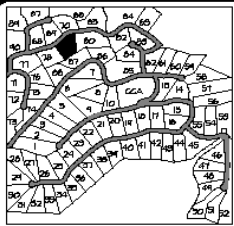

ROCKY KNOB
ESTATES



GREEN MOUNTAIN DEVELOPMENT
INQUIRES: 706-885-6489

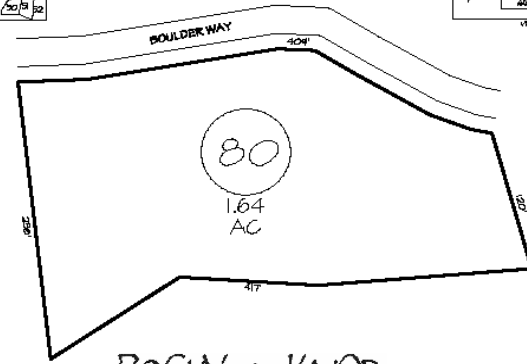
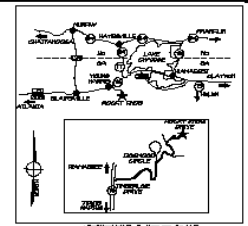
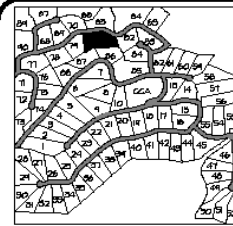

ROCKY KNOB
ESTATES



GREEN MOUNTAIN DEVELOPMENT
INQUIRES: 706-885-6489

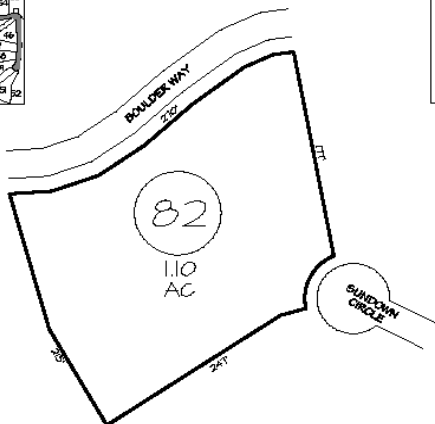
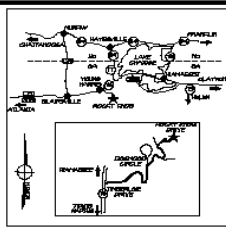
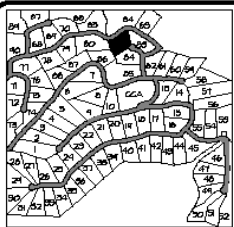

ROCKY KNOB
ESTATES



GREEN MOUNTAIN DEVELOPMENT
INQUIRES: 706-885-6489

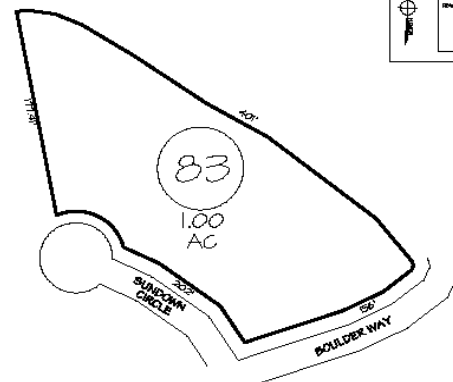
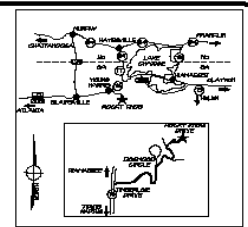
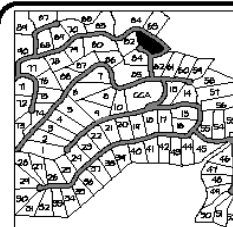

ROCKY KNOB
ESTATES



GREEN MOUNTAIN DEVELOPMENT
INQUIRES: 706-885-6489

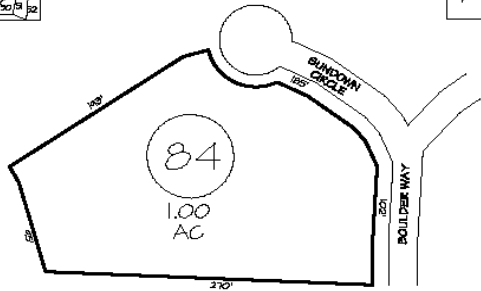
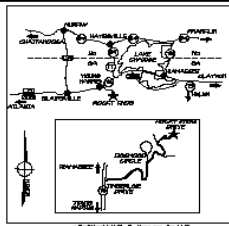
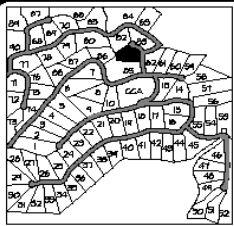

ROCKY KNOB
ESTATES

GREEN MOUNTAIN DEVELOPMENT
INQUIRES: 706-885-6489

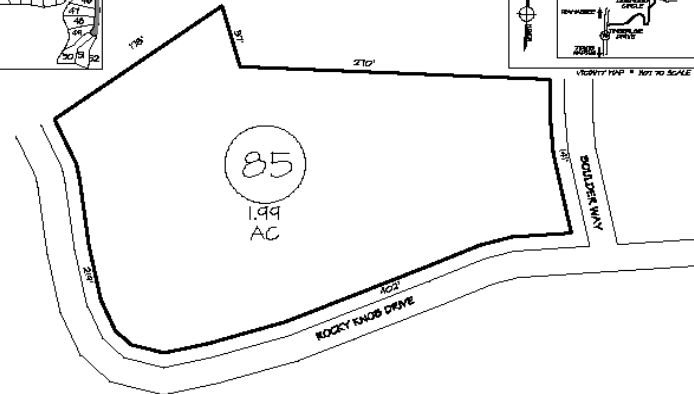
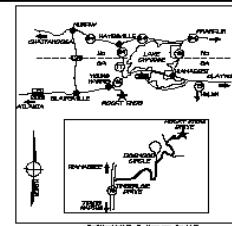
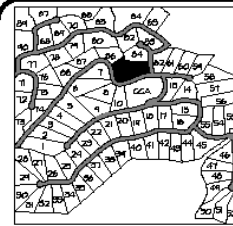

ROCKY KNOB
ESTATES

GREEN MOUNTAIN DEVELOPMENT
INQUIRES: 706-885-6489

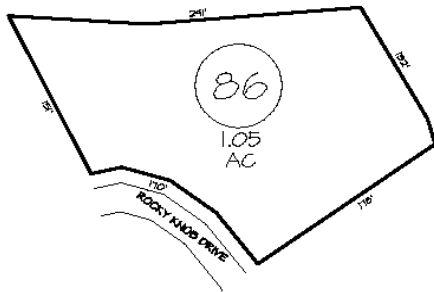
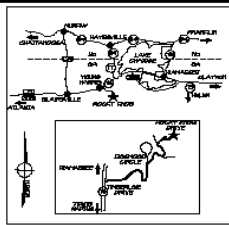
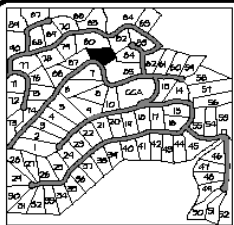

ROCKY KNOB
ESTATES

GREEN MOUNTAIN DEVELOPMENT
INQUIRES: 706-885-6489

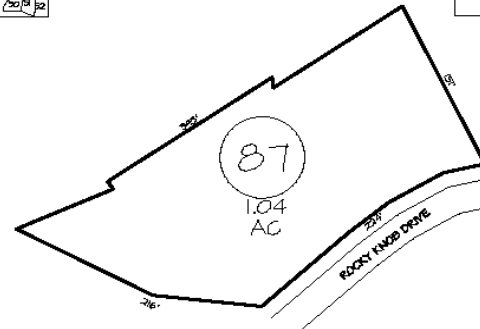
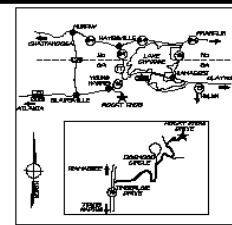
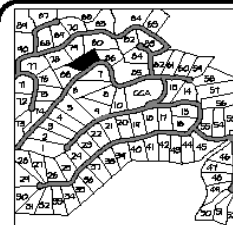

ROCKY KNOB
ESTATES

GREEN MOUNTAIN DEVELOPMENT
INQUIRES: 706-885-6489

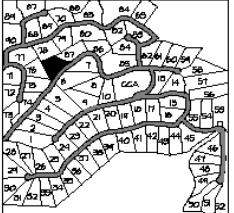
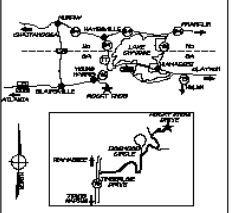
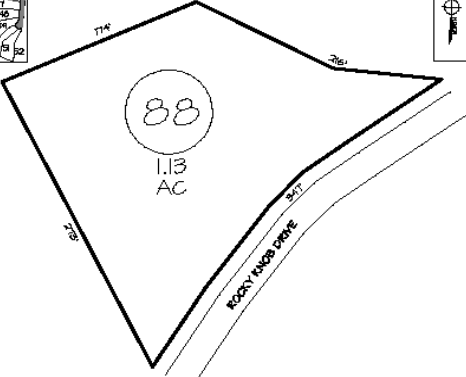



88
1.13
AC

ROCKY KNOB
ESTATES

Landtech
SERVICES, INC.
"See Us By The Thruway"

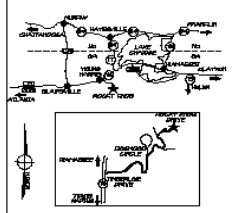
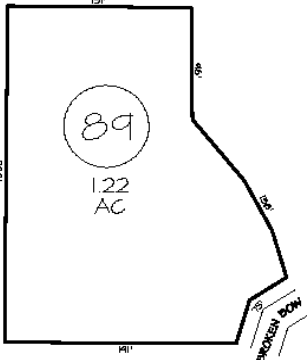
GREEN MOUNTAIN DEVELOPMENT
INQUIRES: 706-885-6488





89
1.22
AC

ROCKY KNOB
ESTATES

Landtech
SERVICES, INC.
"See Us By The Thruway"

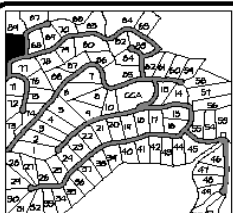
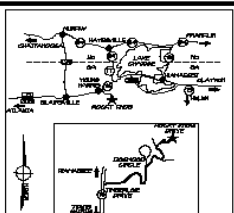
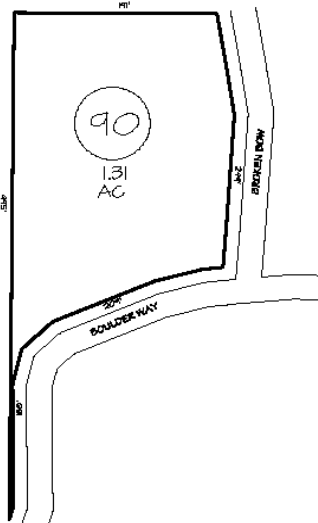
GREEN MOUNTAIN DEVELOPMENT
INQUIRES: 706-885-6488

90
1.31
AC

ROCKY KNOB
ESTATES

Landtech
SERVICES, INC.
"See Us By The Thruway"

GREEN MOUNTAIN DEVELOPMENT
INQUIRES: 706-885-6488

